

# Hardware Random Number Generator

Optional 5V Linear Regulator

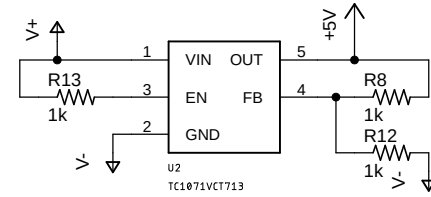

2.5V Reference

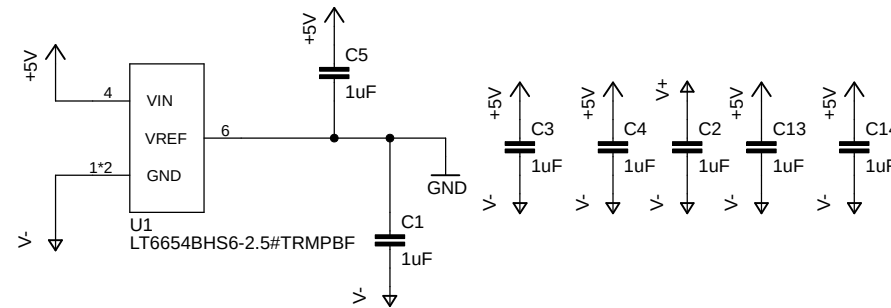

Bypass Cap

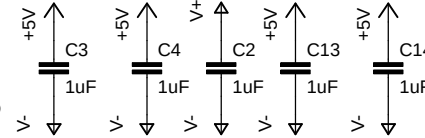

STM32F103 Blue Pill

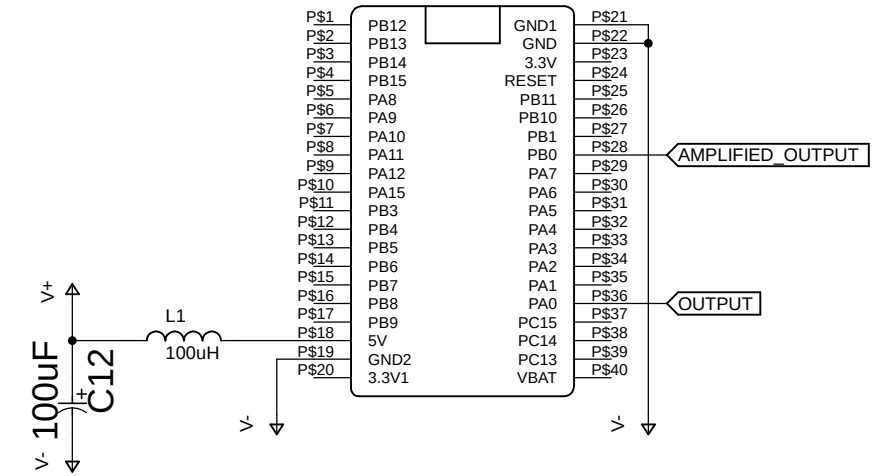

Photodiode

Transimpedance Amplifier  
Input offset: 10uV (typ), 230uV (max)

Output Amplifier: Set Gain with R4/ R5

